

## Properties

The Techlam range of structural flooring is a cost effective alternative to traditional mezzanine floors.

With the potential to achieve a high fire and insulation rating, Structural Glulam Flooring is an obvious choice for mezzanine floors. Often eliminating the need to line ceilings with Gib to achieve required fire ratings – the finished look and natural warmth of timber adds style and character to any décor.

## Features

- Maximises headroom
- Superior fire rating (dependent on required load)
- Rapid assembly on site
- Can be supplied with or without V
- Available in various species
- Supplied as grade A or utility finish
- Eco friendly/sustainable
- Made to length – minimal cutting on site
- Capable of diaphragm action
- Excellent thermal and acoustic insulation

## Installation

Installation of the flooring sections is very simple.

Simply order the required lengths place onto joists and screw or nail into place. In a folded steel joist situation installation can be almost invisible – just screw up from underneath – completely eliminates the need for screws on the surface.

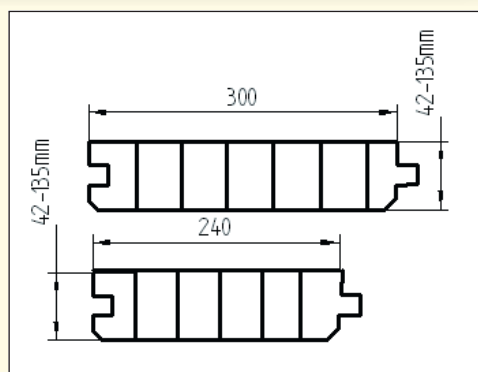

## TECHLAM GL8 GRADE STRUCTURAL LAMINATED FLOORING

Span tables (m) for applied loadings (kPa)

Applied Loading (kPa)	Flooring Thickness (mm)	Single Span (m)	Continuous Spans (m)	Cantilever Length (m)
<b>DOMESTIC</b> 1.5 kPa	42	1.85	2.51	0.87
	65	2.86	3.88	1.35
	90	3.96	5.38	1.86
<b>OFFICE</b> 3 kPa	42	1.47	1.99	0.69
	65	2.27	3.08	1.07
	90	3.14	4.27	1.48
<b>STORAGE</b> 5 kPa	42	1.24	1.68	0.58
	65	1.92	2.59	0.91
	90	2.65	3.59	1.25

### NOTES ON THE TABLES

1. These tables are for information only. Designers are responsible to check every case for strength and deflection and to independently certify every design.
2. Spans given are based on maximum applied load deflections of L/400.
3. Allowances for liveliness are not included in the above static load values.
4. Continuous span values are for all spans loaded.



AS/NZS  
1328  
Lic 2682  
AS/NZS  
1491  
Lic 2683



## **TECHLAM GL8 GRADE STRUCTURAL LAMINATED FLOORING**

### **INFORMATION ON FIRE RESISTANCE RATINGS**

Specific design must be done by a qualified engineer for any application requiring fire rating capacity.

As a general rule, the available resistance rating is dependent on the following factors:-

1. Required live load or applied load.  
The higher the applied load, the lower the available rating.
2. The type of occupancy or use of the floor.  
Industrial or storage areas call for a greater residual load capacity (0.6Q) than residential, offices, parking or retail areas (0.4Q) in AS/NZS 1170.0 clause 4.2.4 and Table 4.1 for post-fire situations.
3. Design factors for strength reduction (f) and load duration (kl) in NZS 3603 can both be increased to 1.0 for post-fire analysis.
4. Charring rates of solid timber and glulam are 0.65 mm per minute; LVL is 0.72 mm per minute.
5. Deflection limits (as for normal loading design) are not specified in NZS 3603 for fire designs as any floor which has been through a fire will need to be replaced; hence residual capacity is essentially for temporary loads only (such as evacuation etc) of brief duration.
6. Generic fire rating tables for different floor thicknesses are given in the NZTIF Timber Design Guide, Chapter 5, Table 5.6 (as shown below).
7. Ratings can be improved by use of an intumescent paint coating on the underside if required.

#### **FIRE RESISTANCE OF GLULAM FLOORING**

(see note 6 above)

<b>Thickness (mm)</b>	<b>Fire Resistance (hours)</b>
<b>65</b>	<b>0.5</b>
<b>90</b>	<b>1</b>
<b>115</b>	<b>1.5</b>
<b>135</b>	<b>2</b>

# TECHLAM GL8 GRADE STRUCTURAL LAMINATED FLOORING –

## SPAN TABLES (m) FOR APPLIED LOADINGS (kPa)



DEPTH (mm)	APPLIED LOADING (kPa)	STRENGTH LIMIT RANGE SPANS	DEFLECTION LIMIT RANGE SPANS											
							A = One span loaded      B = All spans loaded							
			SINGLE SPANS				CONTINUOUS SPANS (DOUBLE OR TRIPLE)							
			L/400	L/300	L/200	L/100	L/400		L/300		L/200		L/100	
A	B	A					B	A	B	A	B			
42	0.5	5.4	2.67	2.94	3.36	4.23	3	3.62	3.31	3.98	3.78	4.56	4.77	5.75
	1	4.06	2.12	2.33	2.67	3.36	2.38	2.87	2.62	3.16	3	3.62	3.78	4.56
	1.5	3.4	1.85	2.04	2.33	2.94	2.08	2.51	2.29	2.76	2.62	3.16	3.31	3.98
	2	2.97	1.68	1.85	2.12	2.67	1.89	2.28	2.08	2.51	2.38	2.87	3	3.62
	2.5	2.68	1.56	1.72	1.96	2.48	1.76	2.12	1.93	2.33	2.21	2.67	2.79	3.36
	3	2.46	1.47	1.62	1.85	2.33	1.65	1.99	1.82	2.19	2.08	2.51	2.62	3.16
	4	2.14	1.33	1.47	1.68	2.12	1.5	1.81	1.65	1.99	1.89	2.28	2.38	2.87
	5	1.92	1.24	1.36	1.56	1.96	1.39	1.68	1.53	1.85	1.76	2.12	2.21	2.67
65	0.5	7.86	4.13	4.54	5.2	6.55	4.65	5.6	5.12	6.17	5.86	7.06	7.38	8.89
	1	6.07	3.28	3.61	4.13	5.2	3.69	4.45	4.06	4.89	4.65	5.6	5.86	7.06
	1.5	5.12	2.86	3.15	3.61	4.54	3.22	3.88	3.55	4.27	4.06	4.89	5.12	6.17
	2	4.52	2.6	2.86	3.28	4.13	2.93	3.53	3.22	3.88	3.69	4.45	4.65	5.6
	2.5	4.08	2.41	2.66	3.04	3.83	2.72	3.28	2.99	3.61	3.42	4.13	4.32	5.2
	3	3.75	2.27	2.5	2.86	3.61	2.56	3.08	2.82	3.39	3.22	3.88	4.06	4.89
	4	3.28	2.06	2.27	2.6	3.28	2.32	2.8	2.56	3.08	2.93	3.53	3.69	4.45
	5	2.95	1.92	2.11	2.41	3.04	2.16	2.6	2.37	2.86	2.72	3.28	3.42	4.13
90	0.5	10.26	5.71	6.29	7.2	9.07	6.44	7.76	7.08	8.54	8.11	9.77	10.22	12.31
	1	8.11	4.54	4.99	5.71	7.2	5.11	6.16	5.62	6.78	6.44	7.76	8.11	9.77
	1.5	6.91	3.96	4.36	4.99	6.29	4.46	5.38	4.91	5.92	5.62	6.78	7.08	8.54
	2	6.13	3.6	3.96	4.54	5.71	4.05	4.89	4.46	5.38	5.11	6.16	6.44	7.76
	2.5	5.56	3.34	3.68	4.21	5.31	3.76	4.54	4.14	4.99	4.74	5.71	5.97	7.2
	3	5.13	3.14	3.46	3.96	4.99	3.54	4.27	3.9	4.7	4.46	5.38	5.62	6.78
	4	4.5	2.86	3.14	3.6	4.54	3.22	3.88	3.54	4.27	4.05	4.89	5.11	6.16
	5	4.05	2.65	2.92	3.34	4.21	2.99	3.6	3.29	3.96	3.76	4.54	4.74	5.71